



# Seismic Isolation

## For Buildings and Bridges

The Best Earthquake Protection  
Technology In The World.



**DYNAMIC ISOLATION SYSTEMS**

Seismic Isolation  
Should Be Your Design Solution  
Because It Provides:

- ♦ Superior Performance
- ♦ Improved Personal Safety
- ♦ Structural Protection
- ♦ Continuous Operation
- ♦ Content Protection
- ♦ Cost Savings



# Table of Contents

## **SECTION 1: Seismic Isolation**

Seismic Isolation	2
Dynamic Isolation Systems	4
Seismic Isolator	5
Sliding Isolator	6
Other Products	6
Floor Isolation	7

## **SECTION 2: DIS Portfolio**

Notable Projects	8
Historic Building Retrofits	9
Hospitals	9
Bridge Retrofits	10
New Bridges	11
Unique Applications	11
Buildings With High Content Value	12
Emergency Centers	12
Projects in Japan	13
Museums	13
Condominiums	13

## **SECTION 3: Engineering**

Isolator Engineering Properties	14
Design and Modeling	16
Terms and Symbols	16
Isolator Testing	17
Frequently Asked Questions	18





## Section 1: Seismic Isolation

**Seismic isolation is a technology that protects the structure from the destructive effects of an earthquake - it decouples the structure from the ground and provides it with damping.**

This decoupling allows the building to behave more flexibly which improves its response to an earthquake. The added damping allows the earthquake energy to be absorbed by the isolation system and therefore reduces the energy transferred to the structure.



**Left:** Utah State Capitol Building, Salt Lake City. **Above:** Golden Gate Bridge, San Francisco, California.

Seismic isolation is physically achieved by placing the structure on isolators. The isolators are laterally flexible elements, yet they are able to carry the vertical loads of the structure. Since the isolators are more flexible than the structure, most of the lateral movements occur in the isolators. As a result the isolated structure experiences less motion and reduced forces.



**DUE TO THE SMALLER MOTIONS AND LOWER FORCES IN THE SUPERSTRUCTURE, LIVES ARE PROTECTED, CONTENTS ARE PRESERVED AND BUILDINGS REMAIN OPERATIONAL.**

The **Design Earthquake** has a 10% probability of occurring during the lifetime of the structure. It will measure from 6.0 to 8.0 on the Richter scale.

### What types of structures are isolation candidates?

- ◆ Hospitals, Bridges and Emergency Centers that require operation during and immediately after an earthquake.
- ◆ Structures with valuable contents or operations such as data centers, communications facilities, high-tech manufacturing facilities and museums.
- ◆ Buildings with high occupancy such as low to medium-rise residences and office buildings.
- ◆ Historic structures.

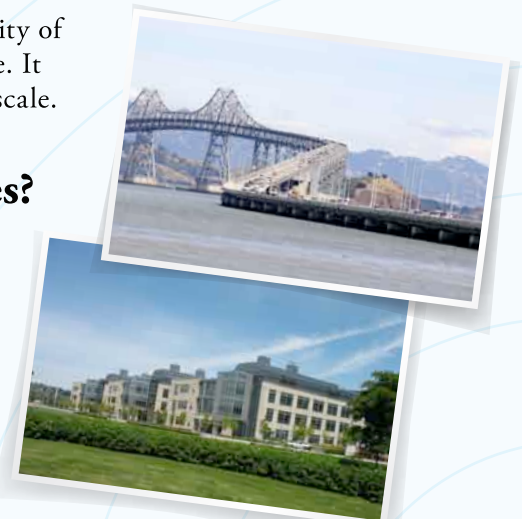



# Seismic Isolation

## What performance can be expected from isolation?

Seismic isolation provides superior performance compared to a traditional structural design. It reduces the forces and displacements in the structure by up to 75%. The isolation system accomplishes this by deforming laterally during the earthquake. After the earthquake this results in a functional structure with little or no damage.

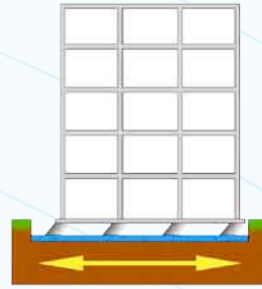

**Seismically Isolated Structure:** The deformation pattern of an isolated structure during an earthquake. Movement takes place at the level of the isolators. Floor accelerations are low. The building, its occupants and contents are safe.

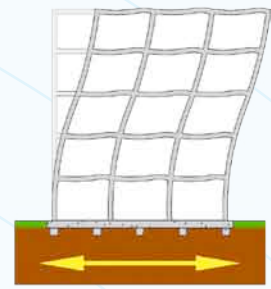

**Conventional Structure:** The deformation pattern of a conventional structure during an earthquake. Accelerations of the ground are amplified on the higher floors and the contents are damaged.



## What performance can be expected from a conventional structure?

Traditional structural design is intended to prevent major failures and loss of life. This design approach does not consider immediate occupation, the maintenance of operation, nor does it provide for easy repair. Traditional design relies on damage to the structure, such as yielding and plastic deformation to dissipate an earthquake's energy. Ductile design of the yielding members helps prevent collapse of the structure. Inherent to this design is the possibility of significant damage to the structure, contents and an inoperable, unusable structure after an earthquake.

**Isolated structures have demonstrated a record of excellent performance during earthquakes.**

## How have isolation systems performed in earthquakes?

The **USC Hospital** was isolated using Dynamic Isolation Systems isolators. The building remained operational throughout the 1994 Northridge Earthquake. There was no damage to the USC Hospital. In contrast the Los Angeles County Medical Center located less than a mile away suffered \$400 million of damage and was not operational after the earthquake.

The **Stanford Linear Accelerator** in Palo Alto, California was unscathed by the 1989 Loma Prieta Earthquake. Elsewhere on campus, damage was reported to be approximately \$160 million.

The **Eel River Bridge** in Humboldt County, California was isolated using DIS isolators in 1988. It experienced accelerations of 0.55g in the 1992 Petrolia Earthquake. The bridge displaced 9 inches laterally and sustained no damage.



USC Hospital, Los Angeles, California.



## How does isolation provide cost savings?

In bridges, the foundation design is based on elastic forces. Isolation reduces elastic forces by up to 75%. This translates into direct cost savings in the foundation. In buildings, isolation provides cost savings over the life of the structure. An isolated building will be essentially undamaged in an earthquake. By comparison, a conventional building's structure and contents will be damaged. The occupants will also experience interruption of their businesses, sometimes for weeks or even months.



# Dynamic Isolation Systems

**Dynamic Isolation Systems played a key role in the development of Seismic Isolation Technology including its commercialization in the 1980's.**

DIS helped to develop codes and provided design and analysis support to engineers and government agencies. Over the past 20 years design earthquakes have increased considerably. DIS has continued to develop its isolators to perform well at large lateral displacements accompanied with high axial loads.



## Isolated Projects

Dynamic Isolation Systems has provided over 12,000 isolators for more than 250 bridges and buildings worldwide. Some prominent projects isolated by DIS include the iconic Golden Gate Bridge, San Francisco City Hall (*left*) that was damaged in the 1989 Loma Prieta Earthquake and Tan Tzu Medical Center in Taiwan. At 1.7 million square feet, it is the largest isolated structure in the world.

## Project Support

Dynamic Isolation Systems can assist you with your feasibility study, budget development and value engineering. We have been able to reduce the cost of the isolation system by up to 30% on projects where we can lend our expertise to the isolator layout and product mix. Our engineers can provide technical support and parameters for structural modeling.

## Manufacturing Capabilities

### ◆ Facility

Dynamic Isolation Systems' 60,000 square-foot manufacturing facility is located in Sparks, Nevada, USA. It is adjacent to Interstate 80 which allows for ease of freight throughout the United States and worldwide via the Port of Oakland in California.

### ◆ Press Capacities

Dynamic Isolation Systems molds in custom-designed and built presses ranging from 200 to 4400 tons. In response to increased demand for larger-sized isolators DIS now has four presses of over 2000 ton capacity. The largest isolators we have manufactured were 60 inches in diameter and weighed 10 tons each.

### ◆ Machining

Steel processing is a major part of manufacturing our isolators. Two large Computer Numeric Controlled (CNC) machining centers process the bulk of our steel plate. They have a capacity to machine up to 80-inch wide plates.

### ◆ Testing

Our main test rig has a shear displacement of  $\pm 31$  inches, a shear force capacity of 700 tons and an axial force capacity of 2000 tons.

Testing is also conducted in a smaller machine that has a shear displacement capacity of  $\pm 12$  inches, a shear force capacity of 100 tons and an axial force capacity of 600 tons.



Over 12,000 isolators have been fabricated by DIS.

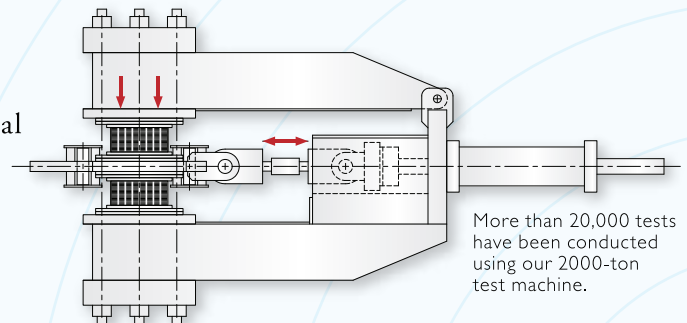

More than 20,000 tests have been conducted using our 2000-ton test machine.



# Seismic Isolator

Isolators consist of a laminated rubber and steel bearing with steel plates which connect to the structure. 90% of our isolators have an energy-dissipating lead core.

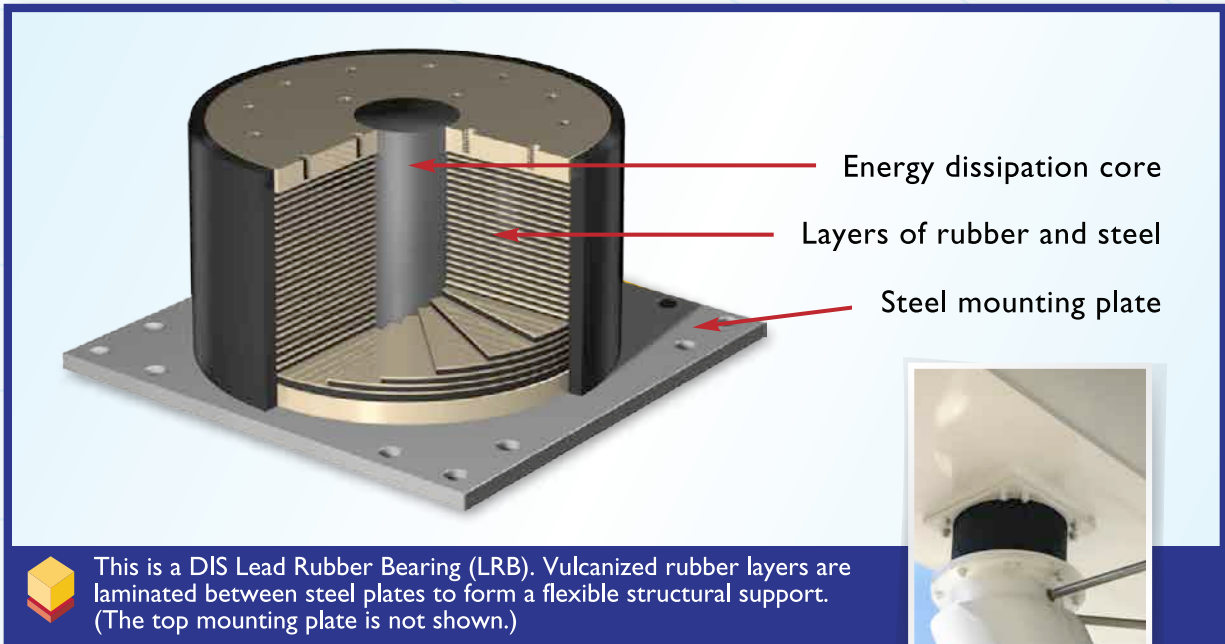

This is a DIS Lead Rubber Bearing (LRB). Vulcanized rubber layers are laminated between steel plates to form a flexible structural support. (The top mounting plate is not shown.)

## Isolator Function

The rubber in the isolator acts as a spring. It is very soft laterally but very stiff vertically. The high vertical stiffness is achieved by having thin layers of rubber reinforced by steel shims. These two characteristics allow the isolator to move laterally with relatively low stiffness yet carry significant axial load due to their high vertical stiffness. The lead core provides damping by deforming plastically when the isolator moves laterally in an earthquake.

## Size Ranges

Isolators from 12 to 60 inches in diameter and capacities of up to 4000 tons are manufactured. Custom dimensions are available for special applications.

## Fabrication

The shims for isolators are cut to exacting tolerances by laser. The steel mounting plates are machined by computer-controlled milling machines that give high production throughput and accuracy. Molding each bearing takes 8 to 48 hours depending on the size of the bearing. The curing phase is continuously monitored to ensure that the rubber is uniformly cured throughout the bearing.

**New construction or retrofits:** For more than two decades Dynamic Isolation Systems has been helping architects, engineers, businesses and institutions match the right earthquake protection technology to the specific needs and requirements of their individual structures.





# Sliding Isolator

A sliding isolator consists of a PTFE (Teflon) disc that slides on a stainless steel plate. A slider may be manufactured with or without an elastomeric backing. The most common slider has the same construction as an isolator with a Teflon disc substituted for the flange plate.

## Slider Function

Sliders support vertical loads and have low lateral resistance. They are typically used in conjunction with isolators and enable the designer to optimize the performance of the isolation system. In some applications they are placed under lighter parts of the structure such as stairs and lightly-loaded columns. The elastomeric backing is used to accommodate rotations in the structure. An added benefit of sliders is that they provide damping from sliding friction.

### Size Range

Sliding isolators have been made from 12 to 41 inches in diameter.

### Slider Manufacturing

Sliders are fabricated with a Teflon disc that mates with a stainless steel sliding surface.

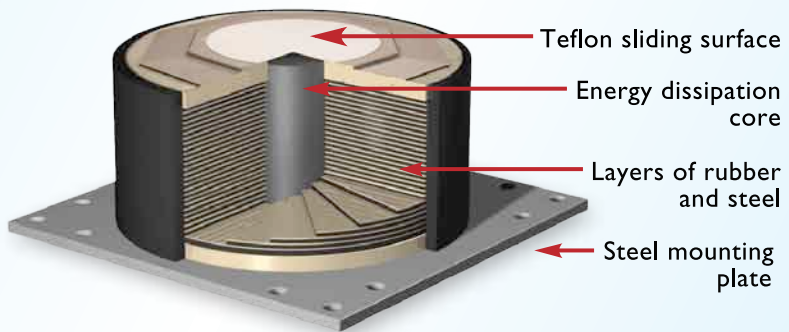

This slider was designed specifically for the Berry Street Project in San Francisco. It was designed to slide for 30 inches, then deform in shear a further 15 inches once it engages a restrainer plate. DIS fabricates and welds all parts of the slider assembly in-house.

# Other Products

## Steelwork and Fasteners

Dynamic Isolation Systems processes over 2000 tons of steel a year. Steel mounting plates, sole plates, anchor bolts and fasteners are often fabricated and supplied with DIS isolators.

## Specialty Bearings

Dynamic Isolation Systems designs and builds bearings for non-seismic applications such as ship loaders. The purpose of the bearings is to control forces within the structure during the off-loading of oil from tankers.



### Richmond San Rafael Bridge:

Dynamic Isolation Systems developed and fabricated bridge bearings for Caltrans with increased corrosion resistance. The bearings are located six feet above the waterline and were fabricated with low permeability rubber and stainless steel construction.



# Floor Isolation

The DIS Floor Isolation System is a newly-developed product. The floor features a recently-invented, multi-directional spring unit that has a very low spring stiffness compared to a building isolator.

Spring stiffness up to 30 lbs/inch is available. The system is modular and can be used as an isolated floor platform or as a whole floor system.

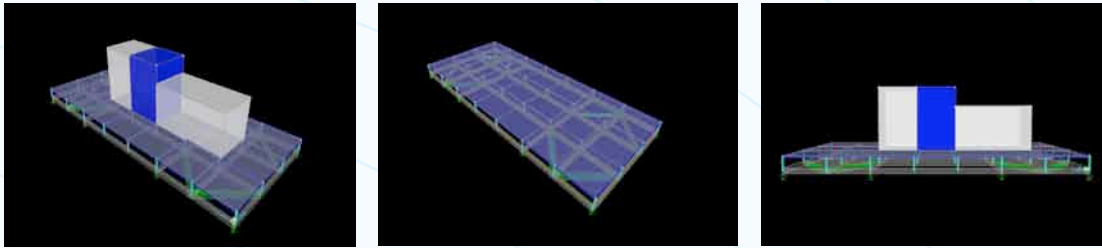

These schematics show the SAP 2000 computer model of a floor that was tested at the University of Nevada, Reno. The floor unit is 14 feet wide by 6 feet deep. There are standard 4 foot by 6 foot modules at each end that are joined by 6 foot long stringers. The modules connect to multi-directional spring units and contain roller and sliding supports. Computer floor tiles make up the top surface of the isolated floor.

## How does floor isolation differ from regular structural isolation?

A Floor Isolation System is installed inside the building and is not part of the structure. Traditional isolation is installed under columns and is an integral part of the superstructure. The same level of earthquake protection can be achieved by both systems.

## When is floor isolation a good design solution?

Floor isolation is a good alternative when isolation of the whole building is not practical or economical. If you are a tenant, the superior performance of isolation can be achieved with floor isolation within the building. Data centers, medical equipment, high-tech manufacturing processes, artwork and valuable products such as vaccines require more seismic protection than a conventionally-designed structure provides.

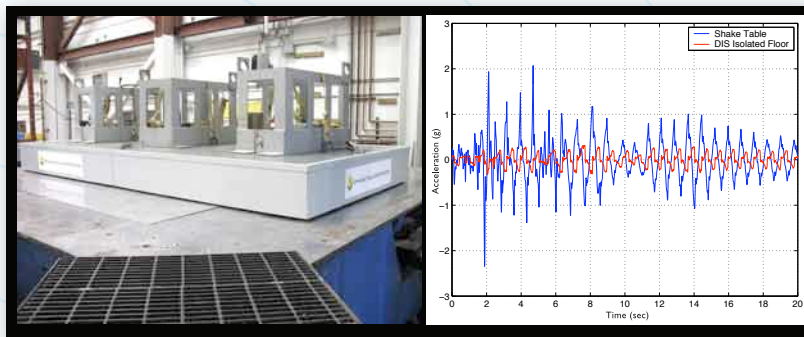

The DIS Isolated Floor System was tested on the shake table at the University of Nevada, Reno. It gave excellent performance that matched our analytical models. For this test, the peak acceleration was reduced from 2g to 0.4g. The spectral accelerations were also reduced by as much as a factor of five.

## What was our first floor isolation project?

The first floor isolation project was the King County Emergency Center in Seattle, Washington. The floor system protected communications equipment and involved isolating a concrete slab with lead rubber isolators and rollers. The new DIS Floor Isolation System is a lightweight solution that will allow its use on any floor of a building.





# Section 2: DIS Portfolio

## Notable Projects

Dynamic Isolation Systems has been at the forefront of seismic isolation for over 25 years. We have supplied isolators for the majority of prominent isolation projects around the world.

### San Francisco City Hall

This West Coast landmark was damaged by the 1989 Loma Prieta Earthquake and has been restored and protected from future seismic activity. 530 DIS seismic isolators were installed, making it the largest seismic retrofitting project in the world.

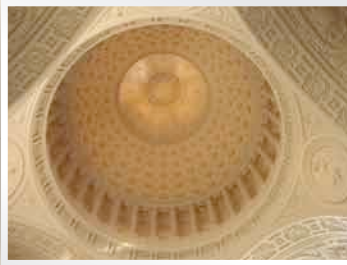

### Salt Lake City and County Building

The City and County Building was the first seismic isolation retrofit in the world. The retrofitted building is designed to withstand earthquakes up to 7.0 on the Richter scale. It is a bearing wall structure constructed of unreinforced brick and sandstone. It was completed in 1894 in the Richardson Romanesque style.



### San Diego Coronado Bay Bridge

This prominent project was the first to feature high-speed testing of isolators. Caltrans built a state-of-the-art test facility at the University of San Diego, California for its toll bridge retrofit program. The test rig was the first to be able to test bearings at actual earthquake velocities. The bearings are designed to accommodate a 1.2 meter fault rupture beneath the bridge.



### Tan Tzu Medical Center

The Tan Tzu Medical Center in Taiwan is currently under construction and at 1.7 million square feet is the largest isolated structure in the world. It is the third hospital in Taiwan for which DIS has provided isolators. Base isolation was chosen so that the hospital would be operational immediately after an earthquake.



## Historic Building Retrofits

Seismic isolation is the best method for upgrading historic buildings to current earthquake design standards. As isolation reduces the forces in the structure, the original architectural fabric of the building can be retained.

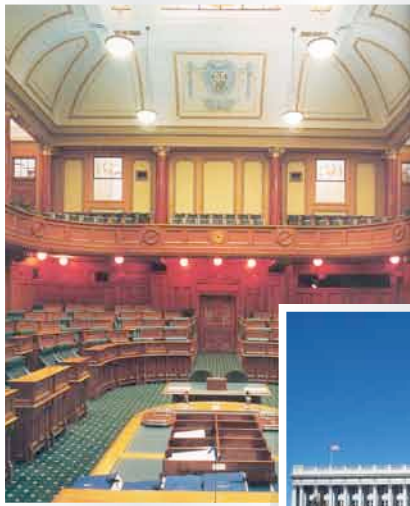

### New Zealand Parliament Buildings

Base isolation was chosen to meet conservation objectives. It allowed the maximum retention of original materials and workmanship within the buildings and avoided any changes to the exterior appearance.

Other historic retrofits using DIS isolators include Oakland City Hall, Kerckhoff Hall at UCLA and Campbell Hall at Western Oregon State College.



### Utah State Capitol Building

The Utah State Capitol Building features Corinthian Architecture and integrates design concepts borrowed from other National Capitols. It was built in 1915. Local materials and custom-designed ornamental features give the building its unique character.

## Hospitals

It is essential that hospitals remain operational after an earthquake. Isolation eliminates damage to the hospital, its operation and protects staff and patients.

### Xindian General Hospital

Testing for this hospital in Taiwan was performed at the University of San Diego to one meter lateral displacement. The shear strain in the isolator was 400% which is well in excess of the demand of the design earthquake. Such testing demonstrates the high performance of DIS isolators. DIS also provided isolators for Hualin and Tan Tzu Hospitals in Taiwan.



Top: Yuzawa Hospital, Japan. Bottom: A slider installed at Takasu Hospital, Japan.



### Erzurum Hospital

Workmen install isolators for Erzurum Hospital in Eastern Turkey. The Turkish Ministry of Health plans to build many new hospitals over the next ten years and is a proponent of superior-performing technology such as base isolation.

### USC Hospital, Arrowhead Medical Center and Long Beach Veterans Administration Hospital

These hospitals are all located in California and fall under the oversight of OSHPD (Office of Statewide Health Planning and Development) with whom we have worked for over 15 years.

EMS

on as strengthening of the existing piers and foundations can  
s the seismic forces in the structure and allows the designer  
hout the structure. DIS isolators have been used in more  
jects.

e  
enefits  
tributed  
solation  
the piers  
to attract  
e structure  
of initial  
. DIS  
isolators  
es.  
e pads



**Rio Vista Bridge**  
Typical location of an isolator in the retrofitted Rio Vista Bridge in California

### Golden Gate Bridge

The North Approach of the Golden Gate Bridge is retrofitted with DIS isolators. Isolation ensures that the bridge will withstand an earthquake of magnitude 8.3.





## New Bridges



### Patria Acueducto

Reduced substructure forces in isolated condition allow for aesthetic expression with sleek members in this bridge in Guadalajara, Mexico. The reduced foundation forces resulted in 50% fewer piles.

### Woodrow Wilson Bridge

This bascule bridge spans the Potomac River near Washington, D.C. This critical bridge which carries over 250,000 vehicles each day, is in a low seismic zone. However, the redistribution of forces and performance under service-load conditions made seismic isolation an appealing option for the designers.



### JFK Light Rail

The elevated JFK Light Rail System connects JFK Airport to the New York subway system. The bridge is ten miles long and is supported by 1,364 DIS isolators. The design-build contractor chose isolation to save foundation costs. As the foundations were smaller, significant other cost savings were realized by minimizing the relocation of underground services at the airport and along the Van Wyck Freeway.

### Mexicalli Bridge

Isolation halved the foundation cost on this bridge in Mexicalli. The foundations required only two-thirds of the concrete and one-third of the reinforcing steel that would have been required with a conventional design.



## Unique Applications

### Berry Street Project

The Berry Street Project in San Francisco features isolation at the roof level of an existing three-story building. Isolation enabled the owner to add two extra stories with minimal strengthening of the existing structure.

As the application is quite unique, testing was conducted to 45 inches of lateral displacement. This is well in excess of the 30-inch design displacement.



Retrofitted water tank in Seattle, Washington.



The **Stanford Linear Accelerator** in Palo Alto, California is protected by DIS isolators.



## Buildings With High Content Value

Isolation also prevents damage to the building contents in the event of an earthquake.



### Hughes S-12 Building

The Hughes S-12 building in Los Angeles is critical to Hughes' satellite operation. The 12-story building remained operational during the retrofit. The likelihood of damage or downtime in the design earthquake has virtually been eliminated.

### Immunex Campus

This Research and Technology Center which is located on Seattle's industrial waterfront hosts immune system studies and drug therapy development. It also houses \$50 million of state-of-the-art equipment. The owner was also concerned that an earthquake could prevent the center from working for several months which would be costly for the corporation.



Television studios and Telecommunications buildings, such as these in Japan, have been isolated for the purpose of avoiding business interruption.



DIS has also isolated Data Centers for Kaiser Permanente, Mountain Fuel and Evans & Sutherland

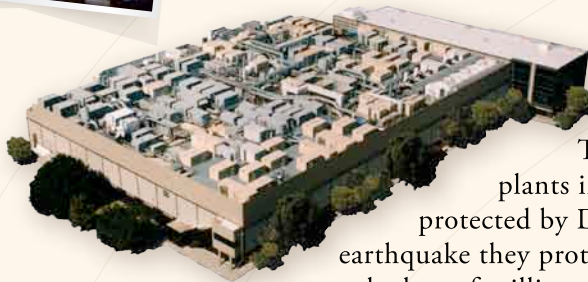

### Conexant Semiconductor Plants

Three Conexant Semiconductor plants in Mexico and California are protected by DIS isolators. In the event of an earthquake they protect assets in the billions and prevent the loss of millions in sales and market share.

## Emergency Centers



### Berkeley Public Safety Building

The Berkeley Public Safety Building is one of many emergency centers built throughout the United States recently. The state-of-the-art building is designed to withstand a

magnitude 7.0 earthquake on the Richter scale and remain operational. It houses the city's 911 Emergency Communication Center which is a vital hub in the city's Emergency Response Plan.



### Long Beach 911 Center

### San Diego Emergency Center





## Projects In Japan

Dynamic Isolation Systems has supplied isolators to more than 80 projects in Japan. Japan has lead the world in using advanced technologies such as base isolation, dampers, buckling restrained braces and tuned mass dampers.



The **Funabashi Fire Station** is one of many fire stations in Japan that are base isolated.



**High City Kyosumi** used 1500mm diameter isolators that were the largest isolators ever built.



**Takasu and Yuzawa Hospitals** use isolators and sliders supplied by DIS.



The **MM21 Building** in Yokohama is a large-scale office project.

Condominiums such as **Fukae Mitsuke** are frequently isolated.



## Museums

Museums are natural candidates for seismic isolation because it provides the best protection available for a building's contents.

### Asian Art Museum

The former San Francisco City Library was retrofitted and now houses more than five billion dollars of Asian artwork and is protected by more than 200 DIS isolators.



### F-Museum

Ten rubber isolators protect this 7-story, 40,000 square foot building in Tokyo, Japan.



## Condominiums

Many residents choose to live in better-protected isolated buildings.



**Channing House**  
Residences in Palo Alto, California.

### Kamikuzawa Condominiums, Japan



Installation of a 1500mm diameter isolator for **High City Kyosumi Condominiums** in Japan.

# Section 3: Engineering

## Isolator Engineering Properties

### Isolator Properties: U.S. Units

DEVICE SIZE				MOUNTING PLATE DIMENSIONS					
Isolator Diameter, $D_I$ (in)	Isolator Height, $H$ (in)	Number of Rubber Layers, $N$	Lead Diameter $D_L$ (in)	$L$ (in)	$t$ (in)	Hole Qty.	Hole $\phi$ (in)	$A$ (in)	$B$ (in)
12.0	5-11	4-14	0-4	14	1	4	1 1/16	2	-
14.0	6-12	5-16	0-4	16	1	4	1 1/16	2	-
16.0	7-13	6-20	0-5	18	1	4	1 1/16	2	-
18.0	7-14	6-20	0-5	20	1	4	1 1/16	2	-
20.5	8-15	8-24	0-7	22.5	1	8	1 1/16	2	2
22.5	8-15	8-24	0-7	24.5	1	8	1 1/16	2	2
25.5	8-15	8-24	0-8	27.5	1.25	8	1 1/16	2	2
27.5	8-17	8-30	0-8	29.5	1.25	8	1 5/16	2.5	3
29.5	9-18	8-30	0-9	31.5	1.25	8	1 5/16	2.5	3
31.5	9-20	8-33	0-9	33.5	1.25	8	1 5/16	2.5	3
33.5	9-21	8-35	0-10	35.5	1.5	12	1 5/16	2.5	3.75
35.5	10-22	9-37	0-10	37.5	1.5	12	1 5/16	2.5	3.75
37.5	10-23	10-40	0-11	39.5	1.5	12	1 5/16	2.5	3.75
39.5	11-25	11-40	0-11	41.5	1.5	12	1 9/16	3	4.5
41.5	12-26	12-45	0-12	43.5	1.75	12	1 9/16	3	4.5
45.5	13-30	14-45	0-13	47.5	1.75	12	1 9/16	3	4.5
49.5	14-30	16-45	0-14	52.5	1.75	16	1 9/16	3	4.5
53.5	16-30	18-45	0-15	56.5	2	16	1 9/16	3	4.5
57.1	17-30	20-45	0-16	60	2	20	1 9/16	3	4.5
61.0	18-30	22-45	0-16	64	2	20	1 9/16	3	4.5

(1) The axial load capacities correspond to maximum displacements based on design limits of 250% rubber shear strain or 2/3 the isolator diameter. An isolator's actual displacement and load capacity are dependent on the rubber modulus and number of rubber layers.

(2) Rubber Shear Moduli ( $G$ ) are available from 55 psi to 100 psi.

(3) For analytical bilinear modeling of the Elastic Stiffness use  $K_e = 10 * K_d$ .

Isolator Diameter, $D_I$ (in)	DESIGN PROPERTIES			Maximum Displacement, $D_{max}$ (in)	Axial Load Capacity, $P_{max}$ (kips)
	Yielded Stiffness, $K_d$ (k/in)	Characteristic Strength, $Q_d$ (kips)	Compression Stiffness, $K_v$ (k/in)		
12.0	1-5	0-15	>250	6	100
14.0	1-7	0-15	>500	6	150
16.0	2-9	0-25	>500	8	200
18.0	2-11	0-25	>500	10	250
20.5	2-13	0-40	>1,000	12	300
22.5	3-16	0-40	>3,000	14	400
25.5	3-20	0-50	>4,000	16	600
27.5	3-24	0-50	>4,500	18	700
29.5	4-27	0-60	>5,000	18	800
31.5	4-30	0-60	>6,000	20	900
33.5	4-35	0-80	>7,000	22	1,100
35.5	4-35	0-80	>8,000	22	1,300
37.5	4-35	0-110	>10,000	24	1,500
39.5	5-36	0-110	>11,000	26	1,700
41.5	5-36	0-130	>12,000	28	1,900
45.5	6-37	0-150	>16,000	30	3,100
49.5	7-38	0-170	>21,000	32	4,600
53.5	8-40	0-200	>29,000	34	6,200
57.1	9-41	0-230	>30,000	36	7,500
61.0	10-42	0-230	>37,000	36	9,000

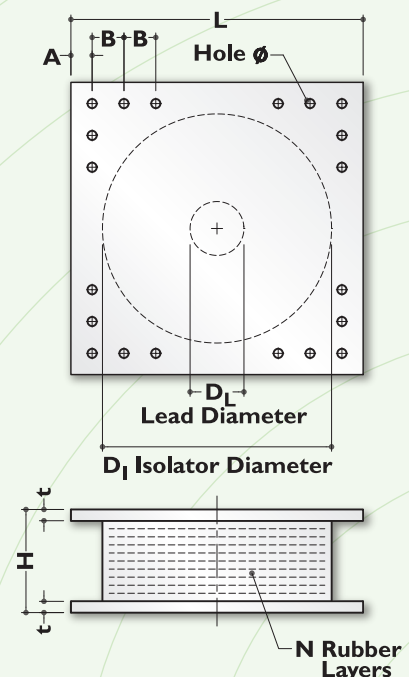





# Engineering

## Isolator Engineering Properties

### Isolator Properties: Metric Units

DEVICE SIZE				MOUNTING PLATE DIMENSIONS					
Isolator Diameter, $D_I$ (mm)	Isolator Height, H (mm)	Number of Rubber Layers, N	Lead Diameter $D_L$ (mm)	L (mm)	t (mm)	Hole Qty.	Hole $\phi$ (mm)	A (mm)	B (mm)
305	125-280	4-14	0-100	355	25	4	27	50	-
355	150-305	5-16	0-100	405	25	4	27	50	-
405	175-330	6-20	0-125	455	25	4	27	50	-
455	175-355	6-20	0-125	510	25	4	27	50	-
520	205-380	8-24	0-180	570	25	8	27	50	50
570	205-380	8-24	0-180	620	25	8	27	50	50
650	205-380	8-24	0-205	700	32	8	27	50	50
700	205-430	8-30	0-205	750	32	8	33	65	75
750	230-455	8-30	0-230	800	32	8	33	65	75
800	230-510	8-33	0-230	850	32	8	33	65	75
850	230-535	8-35	0-255	900	38	12	33	65	95
900	255-560	9-37	0-255	955	38	12	33	65	95
950	255-585	10-40	0-280	1005	38	12	33	65	95
1000	280-635	11-40	0-280	1055	38	12	40	75	115
1050	305-660	12-45	0-305	1105	44	12	40	75	115
1160	330-760	14-45	0-330	1205	44	12	40	75	115
1260	355-760	16-45	0-355	1335	44	16	40	75	115
1360	405-760	18-45	0-380	1435	51	16	40	75	115
1450	430-760	20-45	0-405	1525	51	20	40	75	115
1550	455-760	22-45	0-405	1625	51	20	40	75	115

(1) The axial load capacities correspond to maximum displacements based on design limits of 250% rubber shear strain or 2/3 the isolator diameter. An isolator's actual displacement and load capacity are dependent on the rubber modulus and number of rubber layers.

(2) Rubber Shear Moduli (G) are available from 0.38 N/mm<sup>2</sup> to 0.70 N/mm<sup>2</sup>.

(3) For analytical bilinear modeling of the Elastic Stiffness use  $K_e=10 \cdot K_d$ .

Isolator Diameter, $D_I$ (mm)	DESIGN PROPERTIES			Maximum Displacement, $D_{max}$ (mm)	Axial Load Capacity $P_{max}$ (kN)
	Yielded Stiffness, $K_d$ (kN/mm)	Characteristic Strength $Q_d$ (kN)	Compression Stiffness, $K_v$ (kN/mm)		
305	0.2-0.9	0-65	>50	150	450
355	0.2-1.2	0-65	>100	150	700
405	0.3-1.6	0-110	>100	200	900
455	0.3-2.0	0-110	>100	250	1,150
520	0.4-2.3	0-180	>200	300	1,350
570	0.5-2.8	0-180	>500	360	1,800
650	0.5-3.5	0-220	>700	410	2,700
700	0.5-4.2	0-220	>800	460	3,100
750	0.7-4.7	0-265	>900	460	3,600
800	0.7-5.3	0-265	>1,000	510	4,000
850	0.7-6.1	0-355	>1,200	560	4,900
900	0.7-6.1	0-355	>1,400	560	5,800
950	0.7-6.1	0-490	>1,800	610	6,700
1000	0.8-6.3	0-490	>1,900	660	7,600
1050	0.9-6.3	0-580	>2,100	710	8,500
1160	1.1-6.5	0-665	>2,800	760	13,800
1260	1.2-6.7	0-755	>3,700	810	20,500
1360	1.4-7.0	0-890	>5,100	860	27,600
1450	1.6-7.2	0-1,025	>5,300	910	33,400
1550	1.8-7.4	0-1,025	>6,500	910	40,000

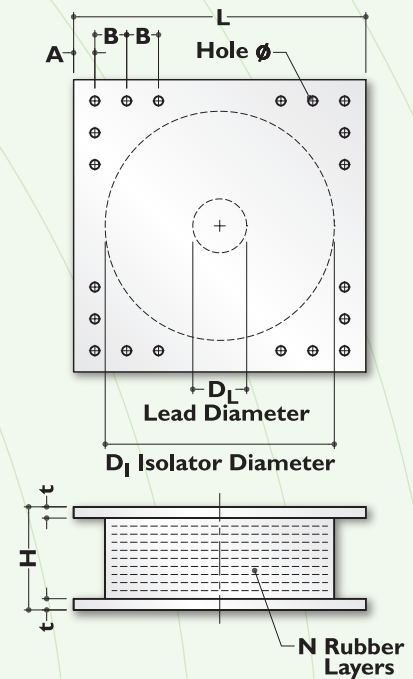



## Design and Modeling

Isolators can be modeled explicitly in analysis software such as ETABS, SAP2000 and LARSA. When software does not support an explicit isolator element, a spring element or a short column may be used to simulate the isolator.

The behavior of a lead rubber bearing is modeled as a bilinear hysteretic element, with an initial stiffness ( $K_e$ ), yield force ( $F_y$ ) and secondary stiffness ( $K_2$  or  $K_d$ ).

For response spectrum analysis the effective stiffness ( $K_{eff}$ ), and the equivalent viscous damping which is derived from the isolator's EDC (Energy Dissipated per Cycle) are required.

For nonlinear time-history analysis, the bilinear properties of the isolator (initial stiffness  $K_e$ , yield force  $F_y$  and the secondary stiffness  $K_2$ ) are used. The vertical stiffness of the isolators is also required as part of the element description. An interesting characteristic of elastomeric isolators is that the compression stiffness is about 100 times the tensile stiffness. Care must be taken in modeling the vertical stiffness to ensure the accuracy of analytical results.

Typical values of these parameters for a wide range of DIS isolators are shown in the Isolator Properties Tables (Page 14 & 15).

DIS can provide specific modeling parameters and assist with the fine-tuning of the isolation system throughout the design process.

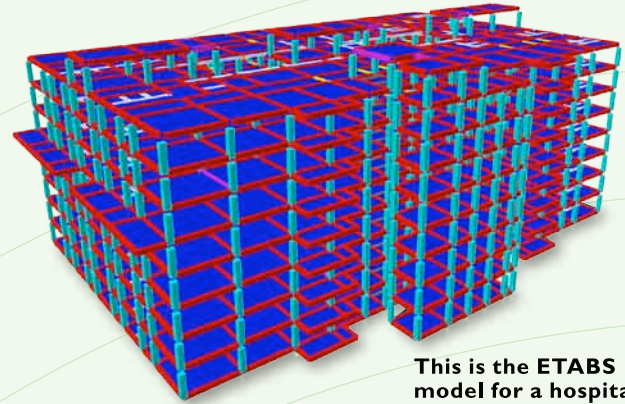

This is the ETABS model for a hospital.

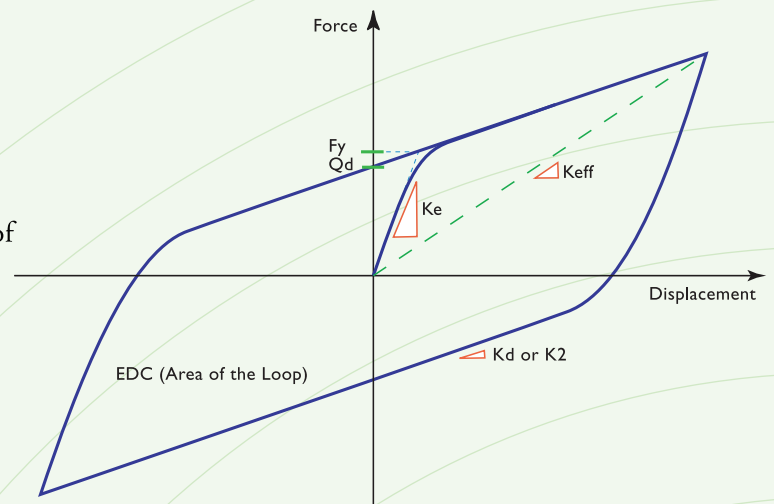

Hysteresis Loop

## Terms and Symbols

**Hysteresis Loop:** This is the force-displacement plot generated by the shear testing of an isolator.

**Elastic Stiffness,  $K_e$ :** This is the initial stiffness of the isolator, typically at less than one inch displacement. Its value is dominated by the lead core size and is important in controlling the response to service loads such as wind.

**Yielded Stiffness,  $K_d$  or  $K_2$ :** This is the secondary stiffness of the isolator and is a function of the modulus, total height and area of the rubber.

**$K_{eff}$  (Effective Stiffness):** This is the isolator force divided by the displacement. This is a displacement-dependent quantity.

**Hysteretic Strength,  $Q_d$ :** This is the force axis intercept of the isolator hysteresis loop. This parameter relates to damping and isolator response to service loads.

**Yield Force,  $F_y$ :** The yield force is the point in the model at which the initial stiffness changes to secondary stiffness. In reality, there is a smooth transition from one stiffness to the other, rather than a well-defined point. This value is mainly used in analytical modeling.

**Energy Dissipated per Cycle, EDC:** This is the area of the hysteresis loop. This value is a measure of the damping of the isolator.

**Vertical Stiffness,  $K_v$ :** This is the vertical stiffness of the isolator.

**DBE (Design Basis Earthquake):** DBE represents the ground motion that has a 10% chance of being exceeded in 50 years.

**MCE (Maximum Credible Earthquake):** MCE is defined as the ground motion that has a 2% probability of being exceeded in 50 years.



## Isolator Testing

The United States codes require testing on each project. Prototype tests validate the isolator properties over the range of the project's loads and displacements. Prototype testing may be eliminated using similarity with previous projects. Production tests check the properties of isolators under the project's load and displacement conditions.

For Japanese projects, extensive testing was performed on our range of isolators over specific stresses and strains. This prequalification testing eliminated prototype testing for individual projects. Only QC testing is done on production isolators which reduces cost and shortens schedules by as much as three months.

### Test Loop

Isolators are tested in pairs at our plant and singly at laboratories such as at the University of California, San Diego (UCSD). The test machine applies a shear displacement and axial load to the isolator. A plot of the test is called a hysteresis loop. The loops below plot the shear force and lateral displacement for the isolator and show the behavior of the isolator for a range of strains up to 300%.

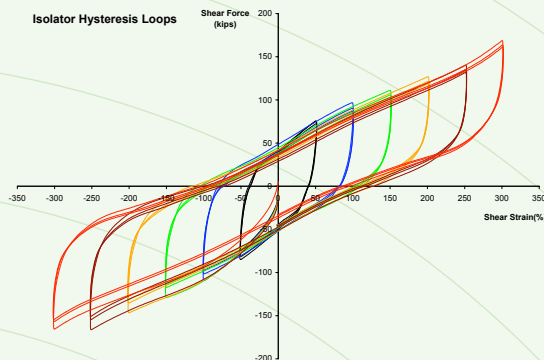

### Real Time Testing

DIS has tested over 30 isolators at actual earthquake velocities of up to 60 inches per second. The tests were performed at the University of California, San Diego. These tests validate the performance of our isolators under seismic conditions and provide detailed velocity data for the isolators. Over 500 tests have been performed over the last seven years on isolators of up to 53.5 inches (1300mm) in diameter.



Bearings for the Coronado Bay Bridge were the first to be tested at earthquake velocities at UCSD for Caltrans.

### Large Strain Testing

DIS has conducted extensive high strain testing on isolators up to 53.5 inches (1300mm) in diameter. Isolators with and without lead cores have been successfully tested to over 400% shear strain. Typical design shear strains are in the 200 to 250% range. Other notable large displacement tests performed by DIS include a 45.5 inch (1200mm) diameter isolator (below) being tested to 45 inches (1140mm) displacement for the Berry Street Project in California.



A 41.5 inch (1100mm) diameter isolator was also tested to 47 inches (1200mm) shear displacement. This bearing was tested as part of a research program for an isolated dam intake structure.

### 1-Mile Wear Test

A one-mile (1.6km) wear test was performed on DIS isolators at the SEES Lab, SUNY at Buffalo. The tests were conducted as part of prototype testing for the new Woodrow Wilson Bridge over the Potomac River in Maryland. This test simulated the effect of a lifetime of thermal expansions and contractions of the bridge deck. The results pictured below show that the isolator's properties were unchanged by this extensive testing.

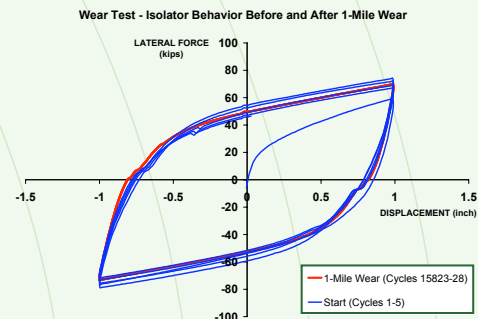



# Frequently Asked Questions

## What does shear strain refer to?

The shear strain is the isolator lateral deformation divided by the rubber height. Design shear strains are up to 250%. DIS has tested isolators to more than 400% shear strain. At that strain each layer of rubber is deformed laterally to four times its thickness. The extreme shear strains in research tests are a testament to the superior manufacturing processes and compounds developed by DIS and provide the isolator with reserve capacity.

## What are typical design displacements?

In high seismic zones such as San Francisco, Tokyo and Istanbul the isolator displacements are up to 30 inches (750mm). For structures located farther from faults or on better soil, the isolator displacements are up to 20 inches (500mm). In low seismic zones such as the eastern United States, movements are in the range of 2 to 6 inches (50 to 150mm). DIS has tested isolators to 47 inches of lateral displacements and provides isolators for all seismic zones worldwide.

## How is the period of the structure shifted?

The fundamental period of the structure is shifted by the addition of flexible isolators. The isolated period is generally more than 2 seconds. The dominant frequencies of an earthquake are in the 0.2 to 0.6 second range. The severe accelerations of an earthquake are avoided due to the period shift provided by isolation (See Diagram 1).

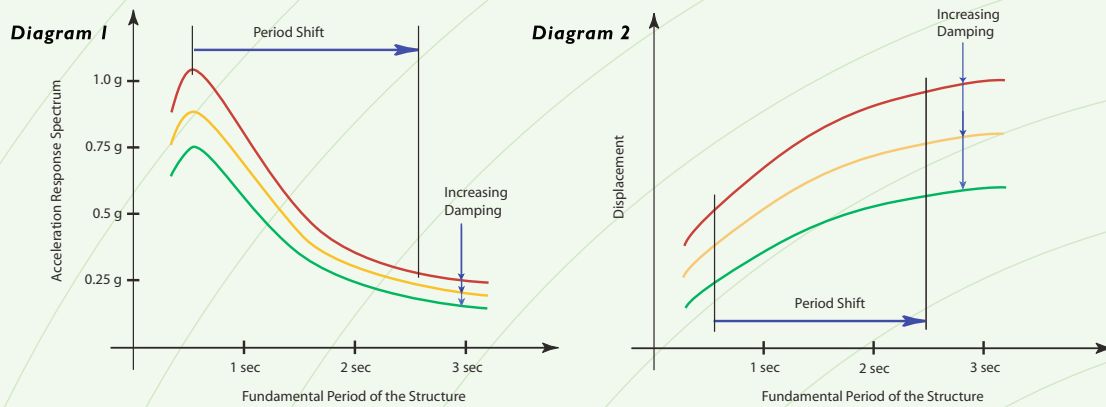

## How is the displacement controlled?

The isolator displacement is decreased by increasing its stiffness or damping. The design trade-off is that forces and accelerations increase as the displacement is decreased.

## How does added damping benefit the structure?

Damping absorbs earthquake energy. The addition of damping reduces the displacements and forces in the superstructure by as much as 50% (See Diagram 2).

## What is the suggested level of damping in an isolation system?

Most structures have 2-5% inherent damping. Isolation systems for bridges typically provide damping levels from 15 to 30%. Isolation systems for buildings have damping in the 10 to 20% range. The building damping levels are optimized to provide low accelerations in the structure which maximize content protection.



## What is the difference of the lead core yield strength at creep loads and earthquake loads?

The hysteretic behavior of lead is dependent on the rate of loading. The yield strength is lower at creep velocities than at earthquake velocities. This is beneficial especially in bridges where the isolator moves over a range of velocities. During the high velocity seismic motion, the yield stress ranges from 10 to 14 MPa, providing significant levels of damping. For thermal movements, the yield stress is in the range of 4 to 6 MPa, which imposes small forces on the structure. Intermediate values of lead stress resist service loads such as wind and braking.

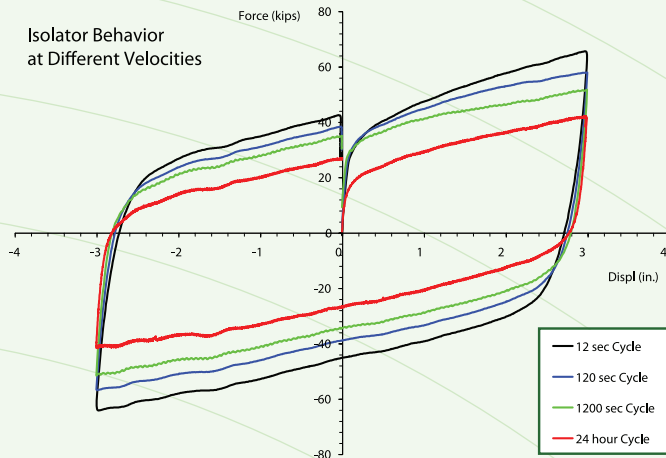

Plotted here are the responses of an isolator over a range of velocities from one cycle in a day to one cycle in 12 seconds. The lead force at low velocity is 60% of that at high velocity.



## Can a tall building be isolated?

Tall buildings such as the 18-story **Oakland City Hall** in California have benefited from isolation. Buildings normally require the isolated period to be 2.5 to 3 times that of the non-isolated building. There are many tall buildings isolated in Japan that have an isolated period in the range of 4 to 6 seconds. The designers chose isolation for the better performance that it provides.

## Does the structure re-center after an earthquake?

A structure re-centers after an earthquake because a restoring force is provided by the rubber. The shaking characteristics also make the structure oscillate at ever-decreasing displacements about its original position as the earthquake motion subsides. The Eel River Bridge in California re-centered after a magnitude 7.0 earthquake to within 1/4 inch of its original position.

## What is the response to the vertical component of an earthquake?

Isolators are stiff in the vertical direction and do not change the vertical seismic response. The vertical component of the earthquake results in axial load variations which can be accommodated in the design of columns and the isolators. Shake table tests have been conducted with and without the vertical component of the earthquake motion. The results indicate that there is very little difference in the performance of the isolators.

## What is the design life of the bearings?

The normal design life of the bearing is over 50 years. Elastomeric pads in highway bridges have been in use for over four decades exhibiting good durability. Isolators with modern rubber formulations surrounded by a protective cover rubber are expected to be more durable and stable in their long-term performance.



### Can more than one bearing be used under a column?

Multiple isolators have been used on San Francisco City Hall and the Tan Tzu Medical Center in Taiwan. Multiple isolators are used when they are more economical than one larger, single isolator.



Groups of four isolators are located under heavily-loaded columns in the Tan Tzu Medical Center.

### Can an isolator resist tension forces?

An allowable tensile stress of up to 50 psi can be applied to an isolator. The actual allowable stress depends on the displacement of the isolator and the rubber modulus. In general tension is avoided in design.

### Does the lead core fatigue?

Lead is in its elasto-plastic phase at ambient temperature. As with other metals in this phase, lead recrystallizes rapidly after being deformed without fatigue.

### How do utilities accommodate movement across the isolation plane in buildings?

Utilities that cross the seismic plane must be detailed to move horizontally. They often are made to be flexible or are fitted with universal joints.



### How are stairways detailed?

Stairways and access points are detailed to be fixed to the superstructure and be “simply supported” on the structure below the isolators. Small sliders are sometimes used to support stairs and accommodate lateral movements.

### How are elevators accommodated?

The bottom section of the elevator is suspended from the superstructure of the building. The framing cantilevers down and is not supported by the substructure. Alternately, the plane of isolation can be lowered several feet locally to allow the elevator pit to be isolated as a part of the superstructure.

### What type of fire protection is needed for seismic isolators?

Fire protection is dictated by the requirements for the fire-space, not by the materials from which the isolator is constructed. When isolators are located in areas of the structure with no fire load, fire protection is often not required. When fire protection has been required, then sprinklers, spray-on mineral fiber, fire blankets and fire board enclosures have been used.



Isolators in the Long Beach 911 Center required no fire protection.



Fire blankets were used in Channing House.



Fire board protects this isolator under the Kamikuzawa Condominiums.

$$\gamma_c = \frac{3P(1 + 8\bar{G}\bar{k}S^2 / K)}{4\bar{G}\bar{k}SA_r}$$



**DYNAMIC ISOLATION SYSTEMS**

885 Denmark Drive, Suite 101  
McCarran, Nevada 89434 USA

Tel: 775-359-3333  
Fax: 775-359-3985  
[www.dis-inc.com](http://www.dis-inc.com)